

BUCKTAIL Twister

INSTRUCTIONS

- STEP #1** Mount the base of the tool in a vise as shown on the packaging.
- STEP #2** Place wire (0.051" - 0.062") onto base as show. Using the handle, bend wire to shape as shown in **SKETCH A**.
- STEP #3** Without removing the wire, reposition the handle and bend the wire one complete revolution in a clockwise direction. Wire should look like **SKETCH B**.
- STEP #4** Insert end of wire into slot as shown, be sure tag end is under "cap" pin as shown. Tighten screw with washer to keep wire in place. Now slide rod end of handle through loop or eye and rotate 3-4 turns counter clockwise. Remove from tool and cut off excess wire (see **SKETCH C**).
- STEP #5** Assemble components as desired and repeat wrap procedure on other end of wire.

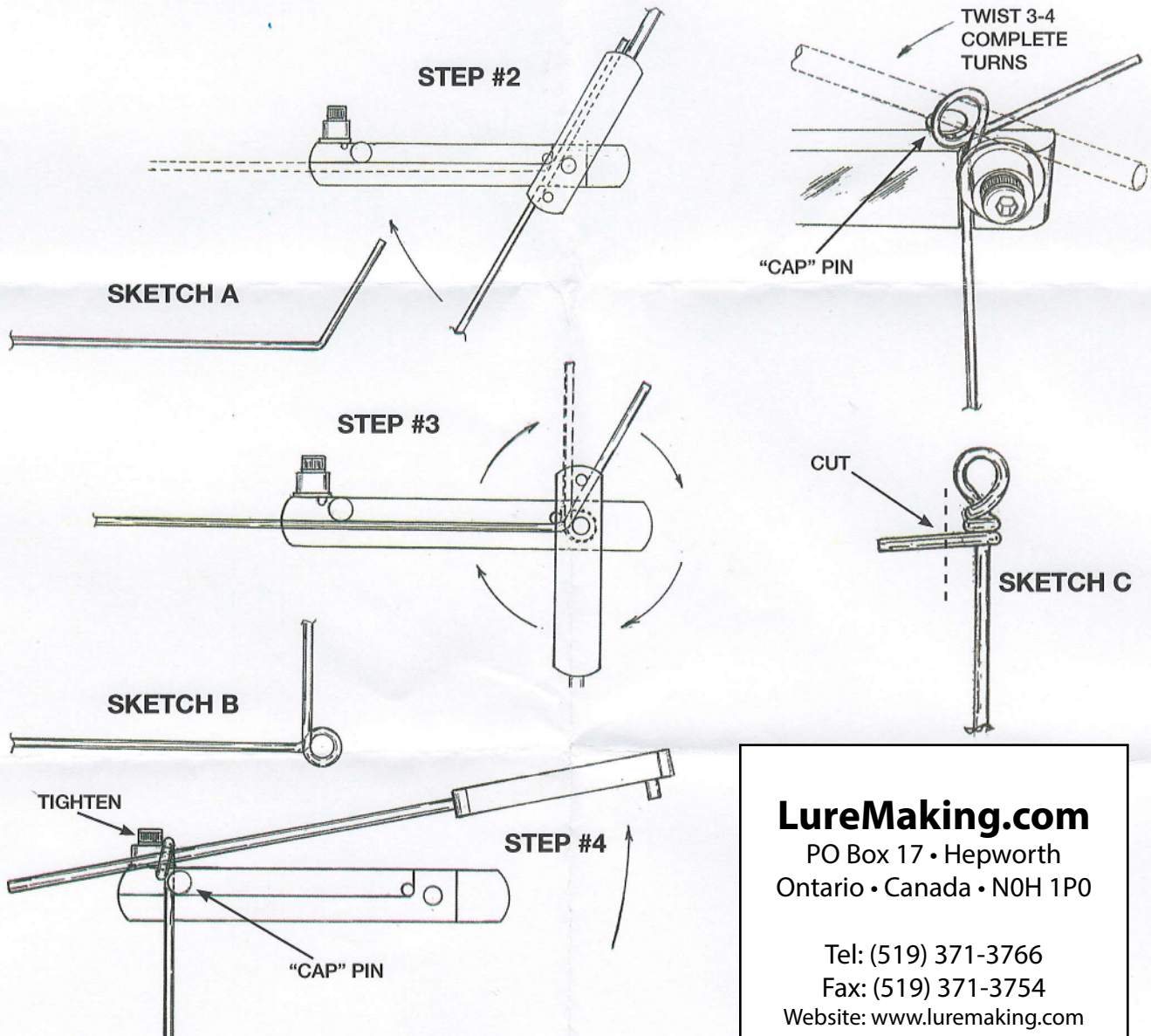

LureMaking.com

PO Box 17 • Hepworth
Ontario • Canada • N0H 1P0

Tel: (519) 371-3766

Fax: (519) 371-3754

Website: www.luremaking.com